



**lughese
macchine utensili s.r.l.**



FOC*ASEIKI*™

Focus on Quality...

WICKER

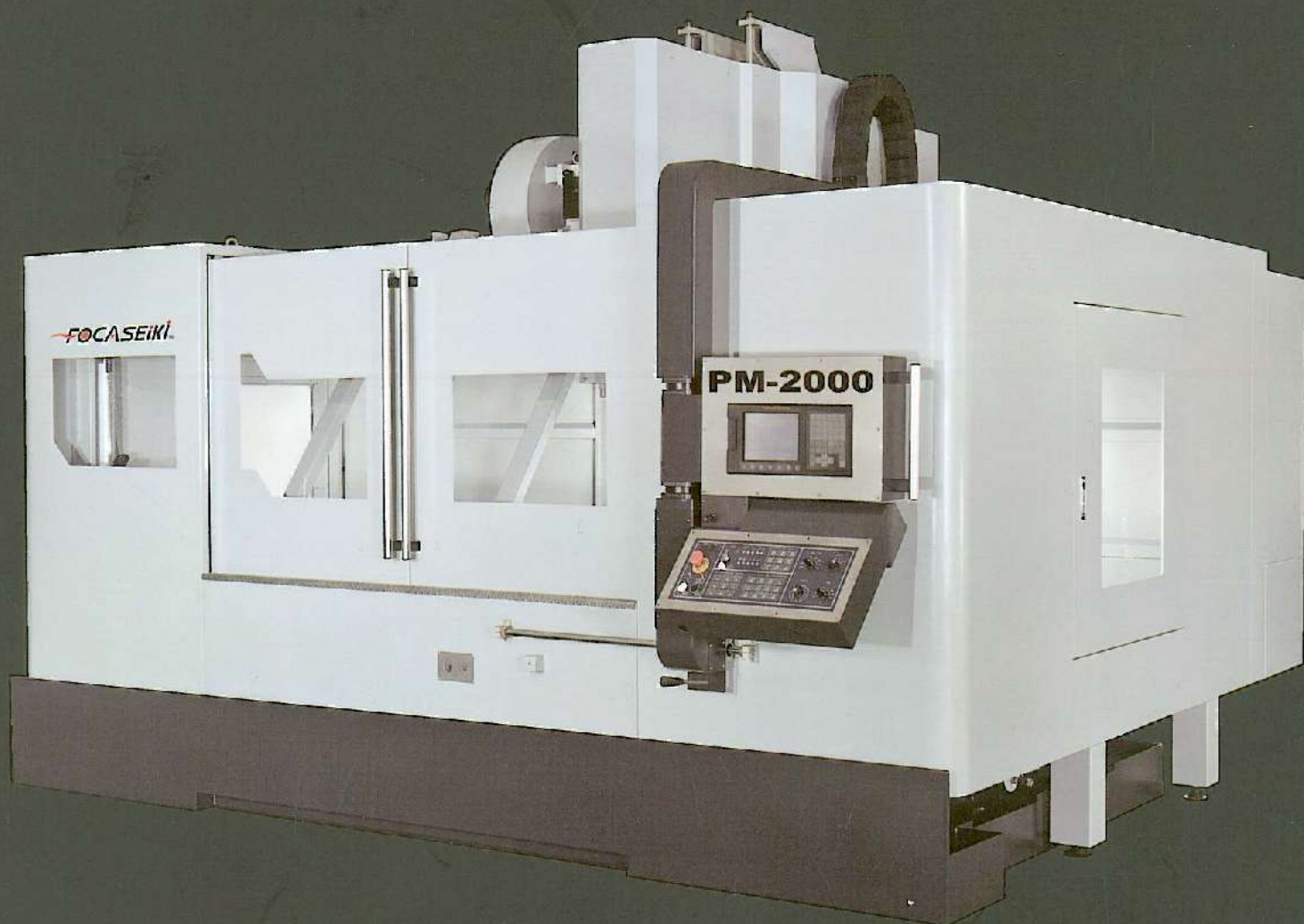

High Rigidity. High Accuracy. Machine

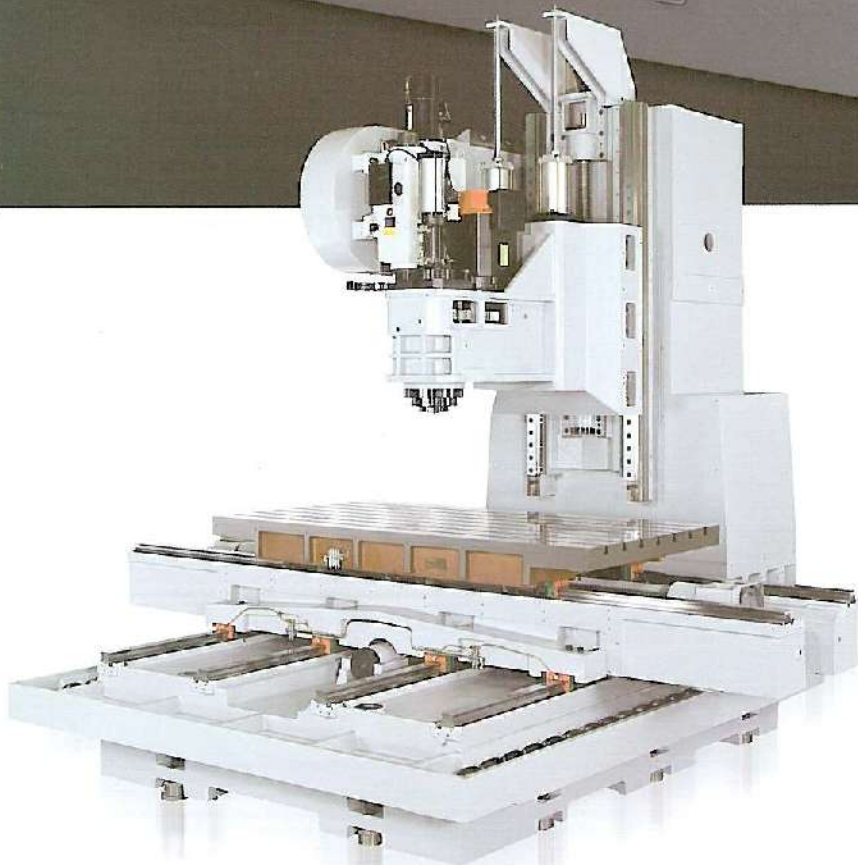

MODEL: 1600/1800/2000

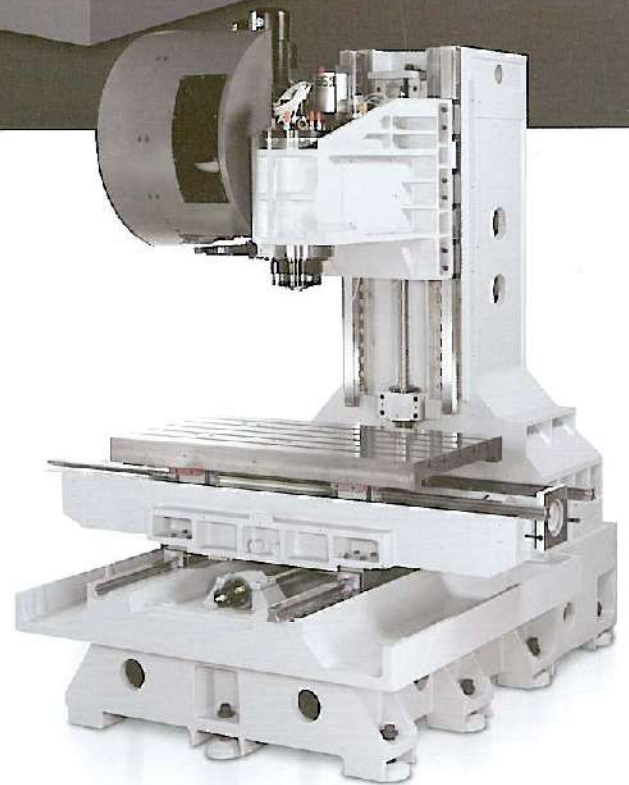

MODEL: 860/1160

MODEL

Design

FOCASEIKI™

Focus on Quality....



AUTO PALLET CHANGE

Pallet dimension	350 x 500 mm
No. of pallet	2
Pallet change time	7 sec. ± 1 sec.
Load of table	250 kgs
Net weight	550 kgs
Gross weight	700 kgs
Floor space	2810x800x3300 mm

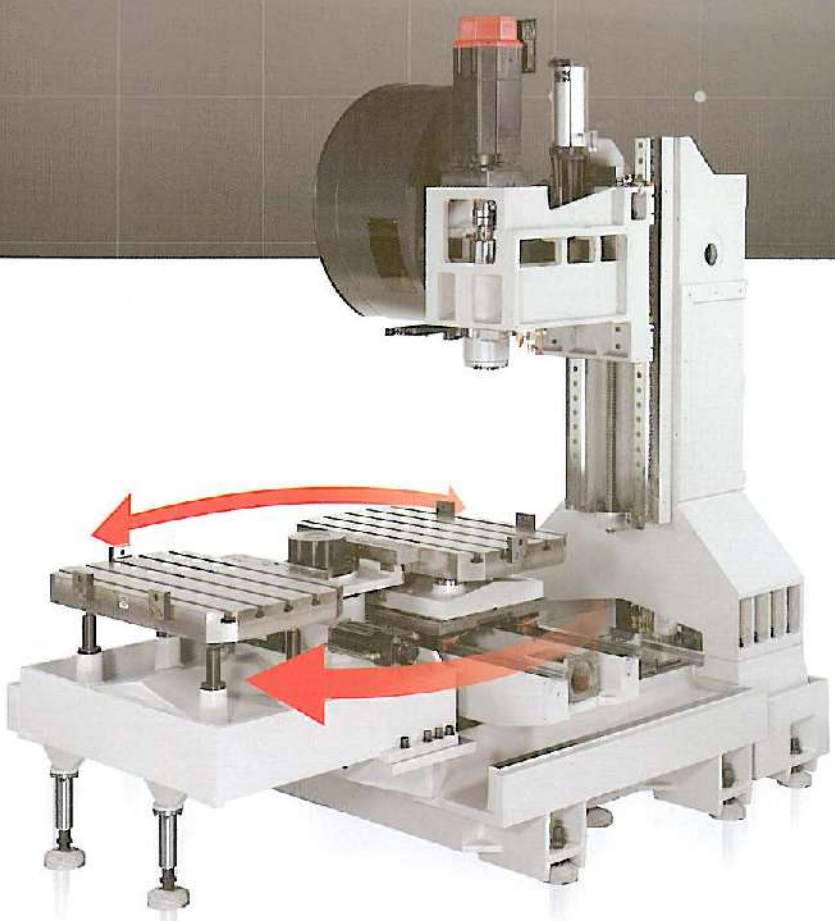
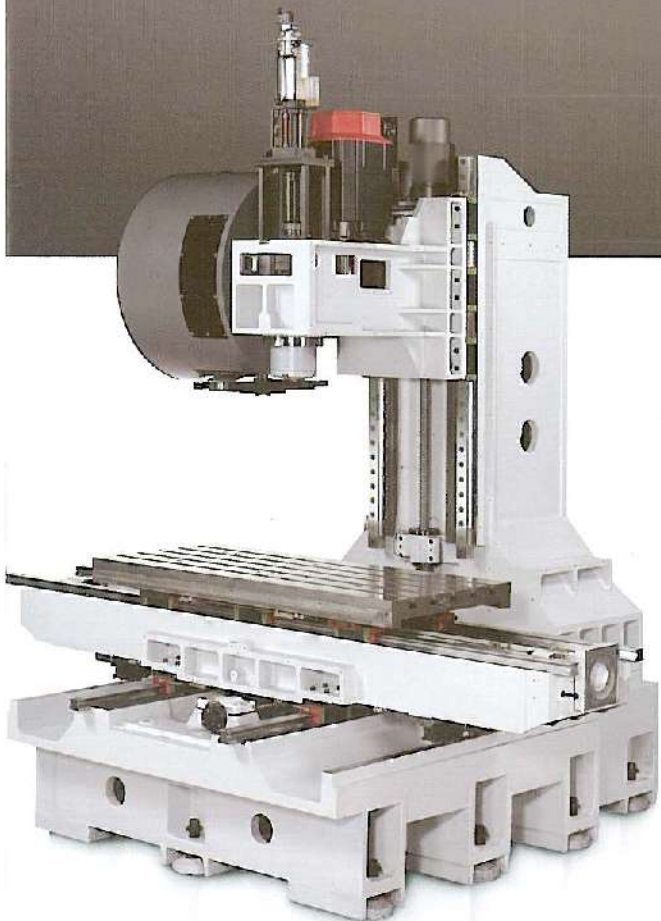

:1100/1250(1350)/1400(1500)

MODEL: 860APC

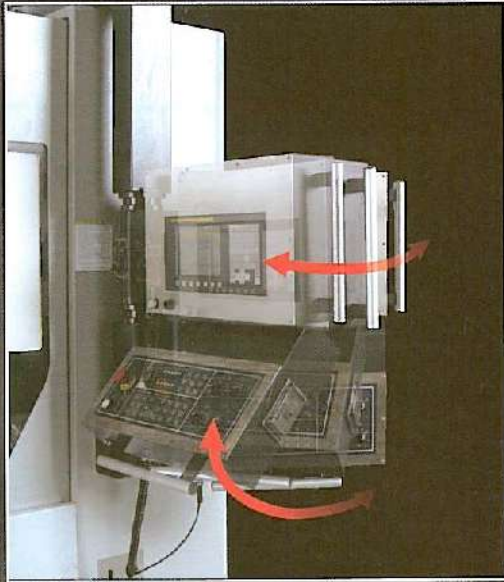

4-WAY SWIVELING
CONTROL BOX



SPINDLE MOTOR
COOLING DEVICE

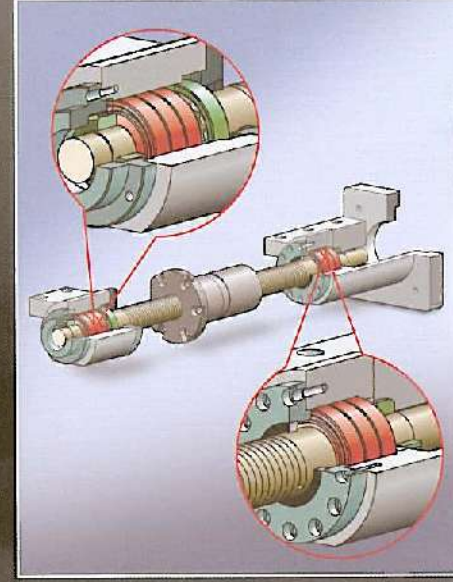

ENHANCED SCREW
PRETENSION DESIGN



Material: NAK 80

Machining programs: Fan Mold

Tool	RPM	mm/min	Machining Time
Ø 10R2	4800	F3000	32 min
Ø 3R3	9000	F3000	38min
Ø 4R2	15000	F2500	70min

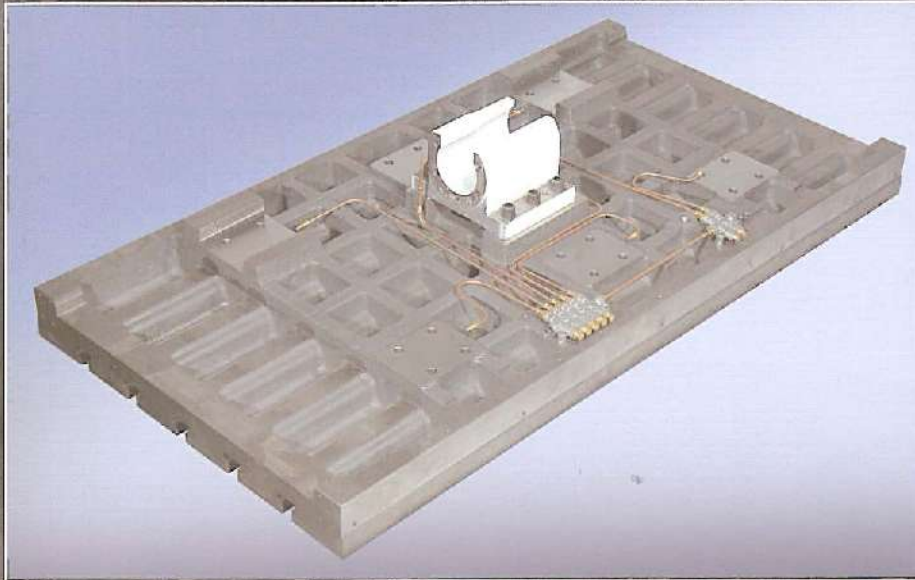

RESERVOIR-TYPE LUBRICATOR BRONZE
TUBE OIL CIRCUIT

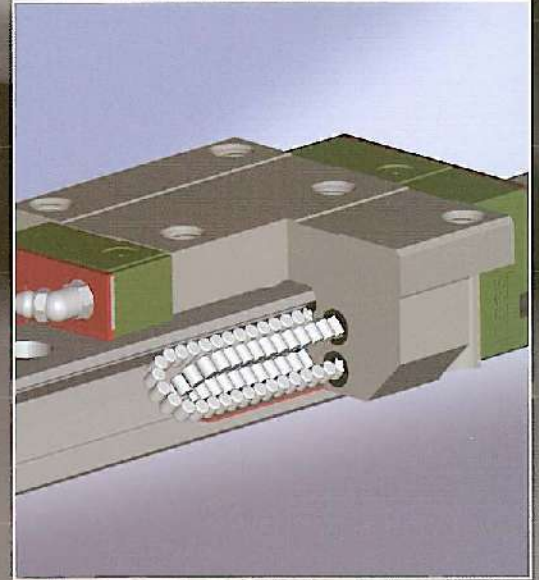

HIGH RIGIDITY ROLLER
TYPE LINER GUIDE

HEIDAINHEIN QAN 260M SERIES

Torque characteristic curve

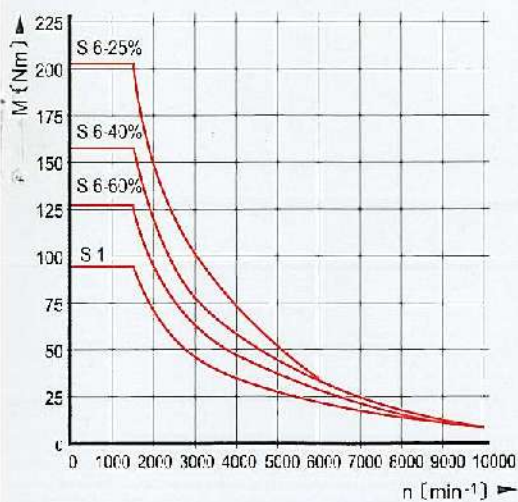

MISTUBISHI SJ-V11 SERIES

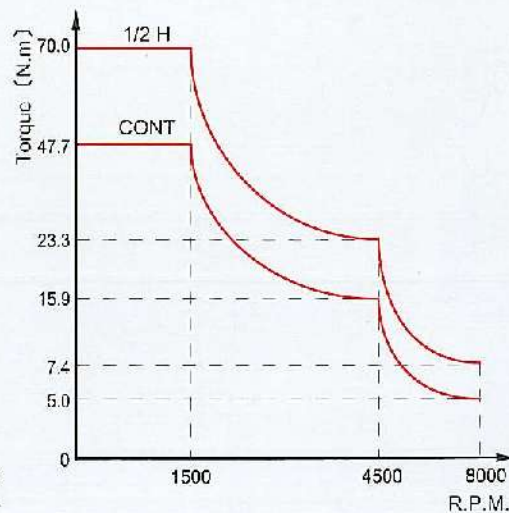

FANUC α SERIES

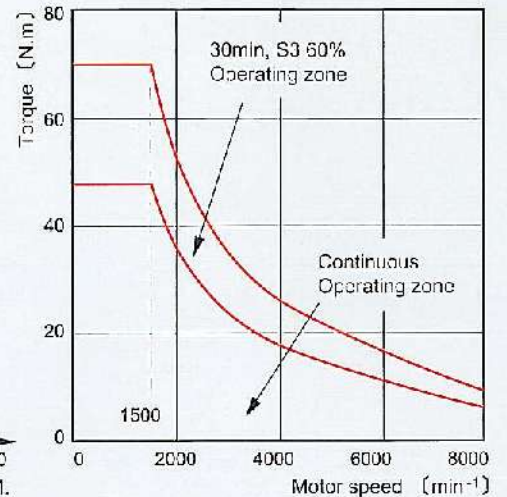

DIMENSIONAL DRAWING :

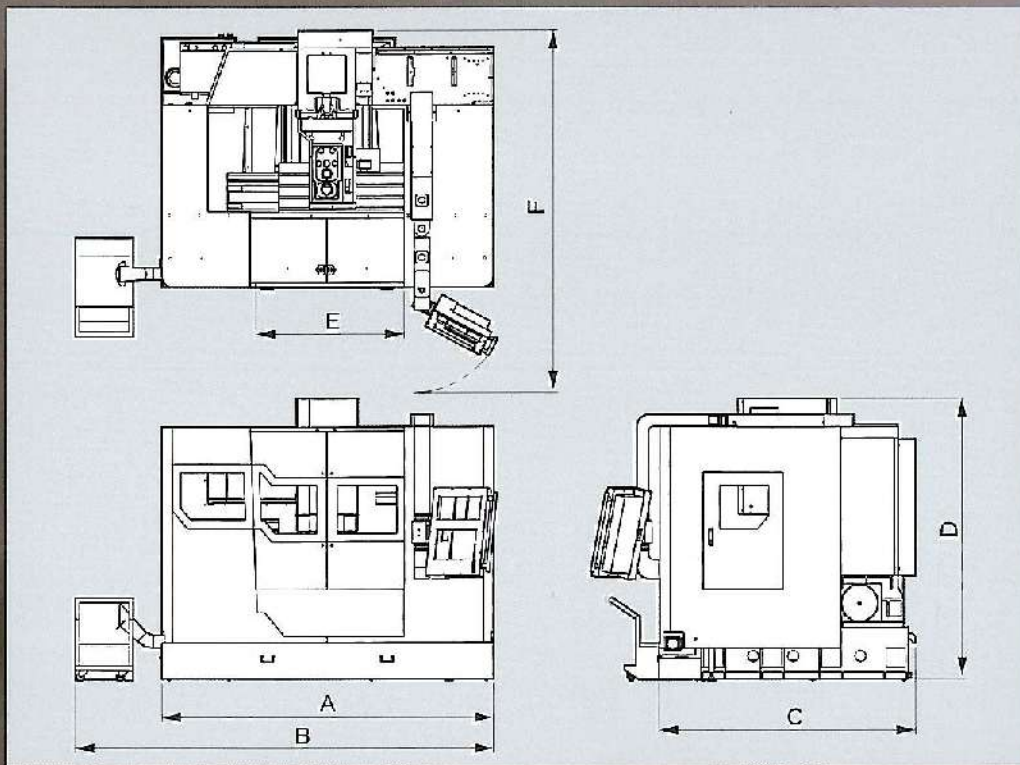

MODEL	A	B	C	D	E	F
860APC	2200	2960	3650	Mini:2380 Max:2980	900	3650
860	2200	2960	2650	Mini:2250 Max:2850	900	3570
1100	2900	3680	2240	Mini:2250 Max:2850	1100	3160
1160	2900	3660	2240	Mini:2340 Max:2980	1100	3160
1250	3200	3980	2260	Mini:2340 Max:2980	1300	3160
1400	3600	4360	2260	Mini:2340 Max:2980	1500	3180
1600	3900	4600	3500	Mini:2500 Max:3500	1700	4500
1800	4200	4900	3500	Mini:2500 Max:3500	1900	4500
2000	4700	5400	3500	Mini:2500 Max:3500	2100	4500

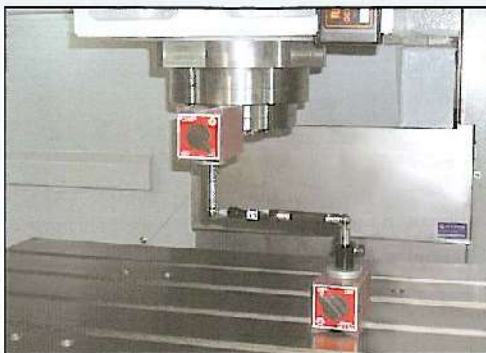

BALL BAR TESTING LASER CALIBRATING SPINDLE
DYNAMIC BALANCING

SPECIFICATIONS :

MODEL

Table

Table size (mm)
Working area (mm)
T - slot (mm)
Max. table loading capacity (kgs)

Travel

X/Y/Z - axis travel (mm)
Spindle nose to table surface (mm)

Spindle

Spindle taper
Spindle R.P.M.
Transmission method
Spindle motor (kw)

Automatic Tool Changer

Magazine capacity
Tool selection method
Max. tool diameter / length (adjacent)
Max. tool weight (kgs)
Tool shank specif.
Tool Change time

Three-axis Motor

X/Y/Z-axis servo motor (kw)
3-axis cutting feed rate (mm/min)
3-axis rapid traverse (M/min)

Dive Motor

Chip auger motor
Chip conveyor motor
Coolant pump motor
Chip flushing pump motor

Coolant Tank

Coolant tank capacity
Coolant flow

Others

Machine dimensions (LxWxH) (mm)
Net weight / Gross weight (kgs)

- We reserve the right to modify the design
- Description in () are optional accessories.

STANDARD ACCESSORIES:

- Arm type automatic tool changer (24 tools)
- Fully enclosed guard
- Swiveling control box
- Work light and alarm light
- Volumetric type automatic lubricator
- Coolant and chip flushing system

860(APC)	1100	1160	1250 (1350)	1400 (1500)	1600	1800	2000
910x560 (850x500)	1100x560	1160x600	1350x600	1500x600	1700x1000	1900x1000	2100x1000
860x600 (860x560)	1100x600	1100x600	1250x700	1400x700	1800x1000	1800x1000	2000x1000
18 x 5 x 100	18 x 5 x 100	18 x 5 x 100	18 x 5 x 100	18 x 5 x 100	18 x 7 x 125	18 x 7 x 125	18 x 7 x 125
800 (250)	900	1000	1200	1500	2200	2500	3000
860/600(560)/600	1100/600/600	1100/600/600	1250(1350)/700/600	1400(1500)/700/600	1600/1000/800	1800/1000/800	2000/1000/800
120~720(110~710)	120~720	120~720	120~720(760)	120~720(760)	200~1000	200~1000	200~1000
ISO 40 (ISO 50) 8000rpm (10000,12000,15000 rpm) / 6000rpm (8000,10000rpm) Belt (Direct, ZF Gearbox) 7.5/11 (11/15 · 15/18.5)					ISO 50 (ISO 40) 6000rpm (8000,10000 rpm) / 8000rpm(10000,12000,15000rpm) Belt (Gear, direct, ZF Gearbox) 15/18.5(18.5/22)		
24 tools (30 tools) Random Ø80 / 300 mm 7 BT-40(CAT-40,DIN, HSK, SK/ISO-50) T-T:2.3 sec.;C-C:4.5 sec.(T-T:1.8 sec.,C-C:3.8 sec.)					24 tools (30, 40 tools) Random Ø110 / 350 mm 15 BT-50(CAT-50,DIN, HSK, SK/ISO-40) T-T:3.5 sec.;C-C:7 sec.		
3.5/3.5/3.5 B(M);3.0/3.0/4.0 B(F) 12000 30/30/24 (36/36/30,48/48/36)					4.5/7.0/7.0 B 10000 20/20/15(24/24/20)		
1/2 HP 1/4 HP 3/4 HP 1/2(3/4) HP					1/2 HP 1/4 HP 3/4 HP 1/2(3/4) HP		
350 L	400 L	400 L	400 L	400 L	600 L	700 L	750 L
200 L/min	200 L/min	200 L/min	200 L/min	200 L/min	200 L/min	200 L/min	200 L/min
2960x3570(3650)x2980	3660x3160x2850	3660x3160x2980	3960x3160x2980	4360x3160x2980	4800x4500x3500	4900x4500x3500	5400x4500x3500
6000/6600(7300/8000)	6700/7300	7300/7800	8000/8500	10000/10600	17000/20000	18000/21000	20000/23000

and specifications without notice in advance. Above specifications are for reference only. Correct specifications are based on actual machine.

OPTIONAL ACCESSORIES:

- Auto power off
- Rigid tapping
- Tool box
- Leveling screws & blocks
- Operation manual
- Mechanical oil coolant separator
- Air gun
- Water gun
- Coolant through tool holder
- Coolant through spindle(CTS)
- Transformer
- Chip conveyor
- Linear scale
- CNC rotary table
- Automatic tool probe
- ZF gearbox
- Spin window
- 30, 40 tools

Powered By Technology Knowhow and Experience.



lughese
macchine utensili s.r.l.

Via Piratello 59/3 - 48022 Lugo (Ra) ITALY • Tel. +39 0545 31905 Fax +39 0545 32055
e-mail: info@lughese-macchine.it web site: www.lughese-macchine.it • P.Iva 02105840397