

XMF XMS SERIES



VISION WIDE TECH CO., LTD.

No. 1126-2, Bishan Rd., Caotun Township, Nantou 542, Taiwan
Tel: +886-49-2338888
Fax: +886-49-2330083

VISION WIDE AH TECH CO., LTD.

No. 165 Industrial Rd, Danyang Town, Bowang Dist.,
Maanshan City, Anhui, China
Tel: +86-05552908886

E-mail: info@visionwide.com.tw
www.visionwide-tech.com



XMF/XMS-E-202210

XMF/XMS SERIES

EXTREMELY MIGHTY MACHINING CENTER





**VISION
WIDE**
Solution . Satisfaction . Smile

XMF/XMS *SERIES*

EXTREMELY MIGHTY MACHINING CENTER

Everyday /
Everything we know

Vision Wide's machines are processing their parts all over the world

XMF/XMS Moving Column Machining Center

- Huge workpiece machining space.
- Excellent moving column positioning accuracy.
- High torque spindle with heavy-duty capability.
- Fully automatic tool changer.
- Fully automatic multi-face machining.
- Friendly operation interface.
- Milling and turning compound solution.
- Thermal friendly Box-in-Box cross beam.
- High geometric accuracy.



Manufacturing Fundamentals of Large-Scale Precision Machine

- Environment temperature control under 1° C
- 75 ton/m² endurance of foundation
- Humidity below 75%

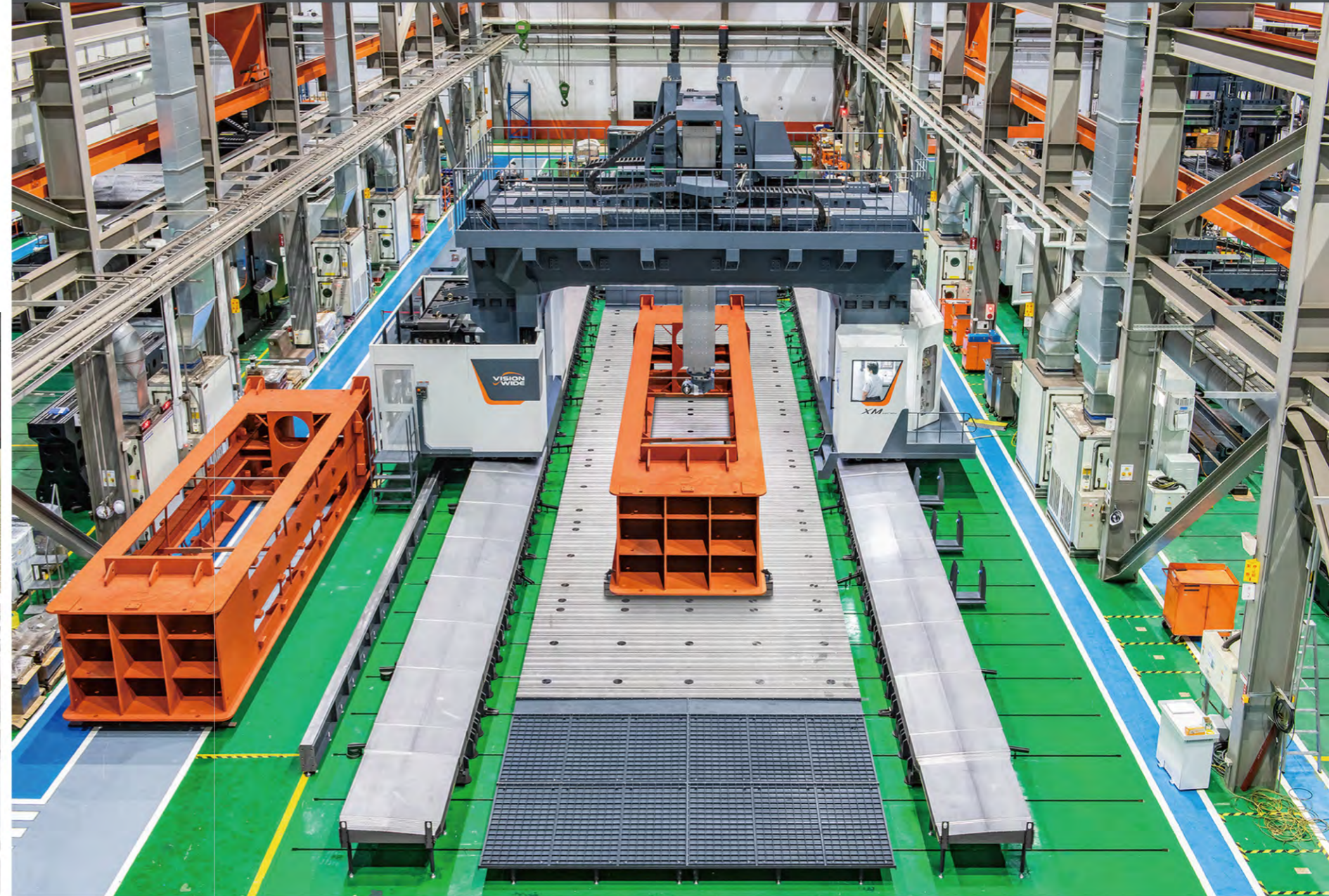

XMF/XMS Large Machining Travel

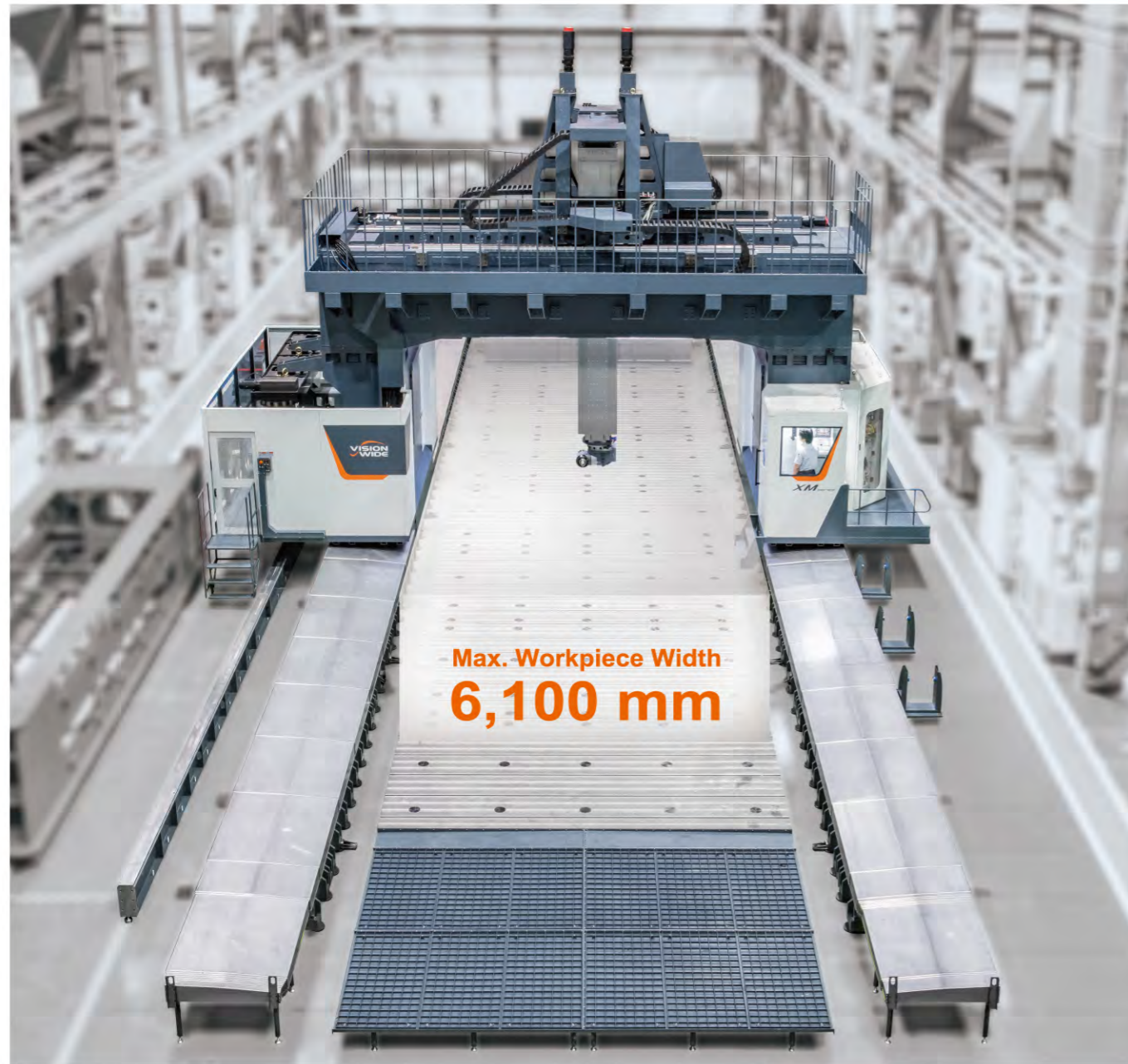

Max. Workpiece Width
6,100 mm

XMF

X axis travel: 8,200(+1m)~60,200 mm
Y axis travel: 4,200/ 4,700/ 5,200/ 5,700 mm
Z axis travel: 2,500/ 3,000 mm
Max. Table load: 5,000 kg/m²
Max. Workpiece Height: 3,500 mm
Max. Workpiece Width: 6,100 mm

XMS

X axis travel: 8,200(+1m)~60,200 mm
Y axis travel: 2,700/ 3,200/ 3,700/ 4,200/ 5,200 mm
Z axis travel: 1,500/ 1,800/ 2,000/ 2,200 mm
Max. Table load: 5,000 kg/m²
Max. Workpiece Height: 2,700 mm
Max. Workpiece Width: 5,600 mm

※ Please contact sales for more details.

X-axis structure

- Single rack-pinion with dual linear rails design, each side of the rail is equipped with 2 sliding blocks, a total of 10 sliding blocks.
- Provides optimal moving load, rapid feed 15m/min.
- Dual linear encoder positioning feedback system

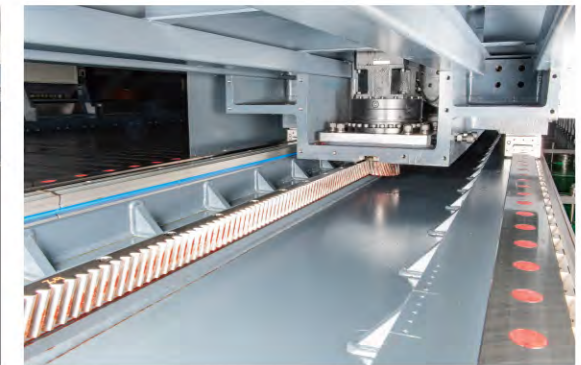

Y-axis structure

- Box-in-Box cross beam design, equipped with high rigidity support of 16 sliding blocks with 4-linear rails.
- Provides optimal moving load, rapid feed 15m/min.



High Geometric Accuracy Machining Performance

Large-scale rigid design and high-precision structural provide high geometric accuracy

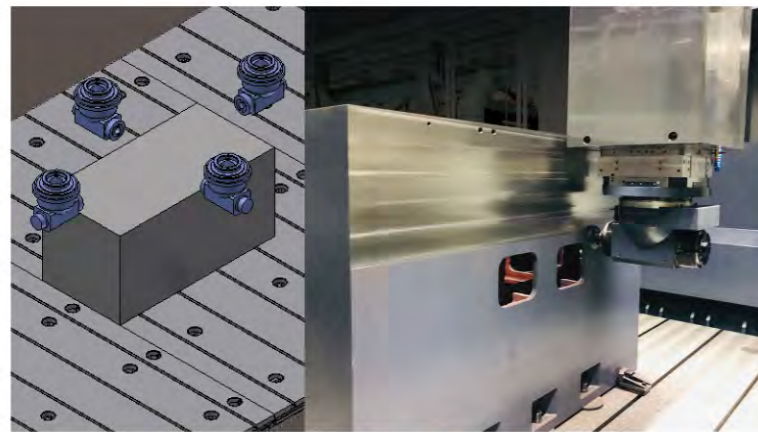

● Actual Machining case

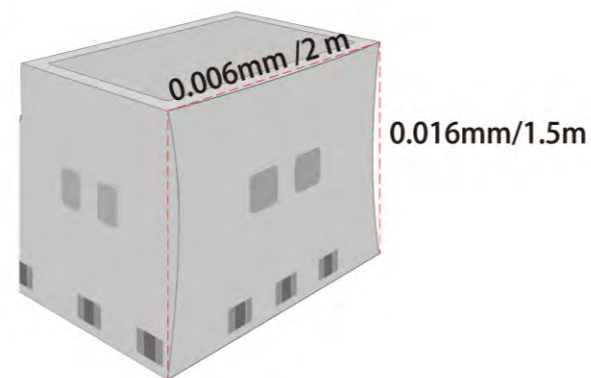

Extremely Moving Column Drive Technology Achieve High Efficient Manufacturing Capabilities



High Precision and High Torque Large Opposite-Boring

1. Cylindricity: 0.0150mm
2. Holes' Coaxiality: 0.0135mm

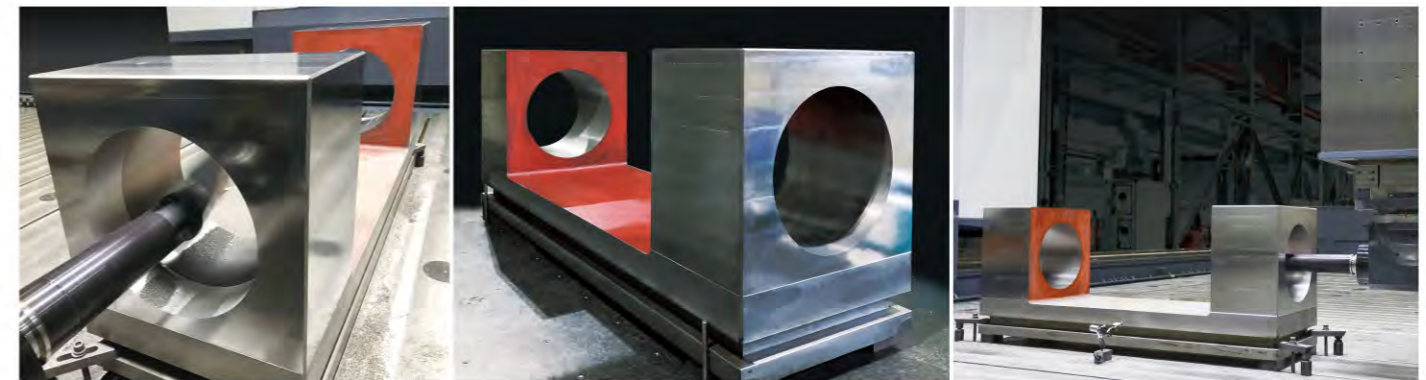
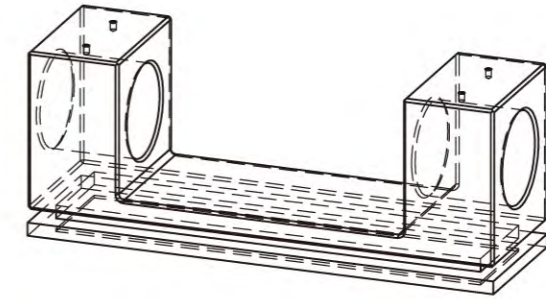

● Actual Machining case

Ambient Temperature Compensation, ATC

When the machining is processed under the non-fixed temperature environment and also the change of the thermal displacement of the machine structure, the accuracy of the machining products would be affected.

ATC is based on the thermal displacement phenomenon of the machine structure, through the temperature and feed position information returned by the sensor to calculate the thermal displacement value of the machine structure caused by the environmental temperature variation, and accurately control it.

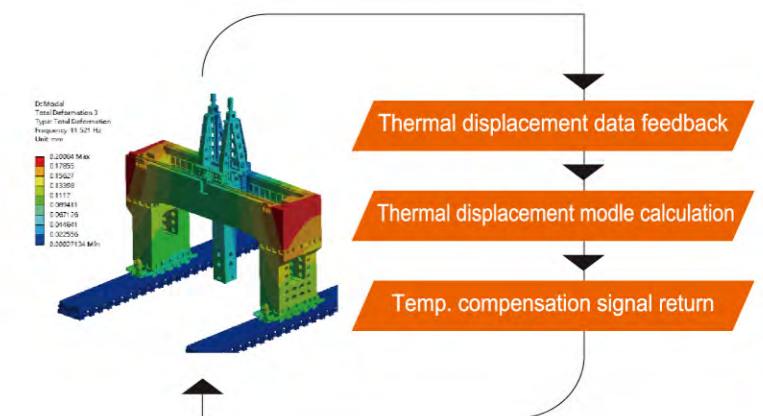

Z-axis structure

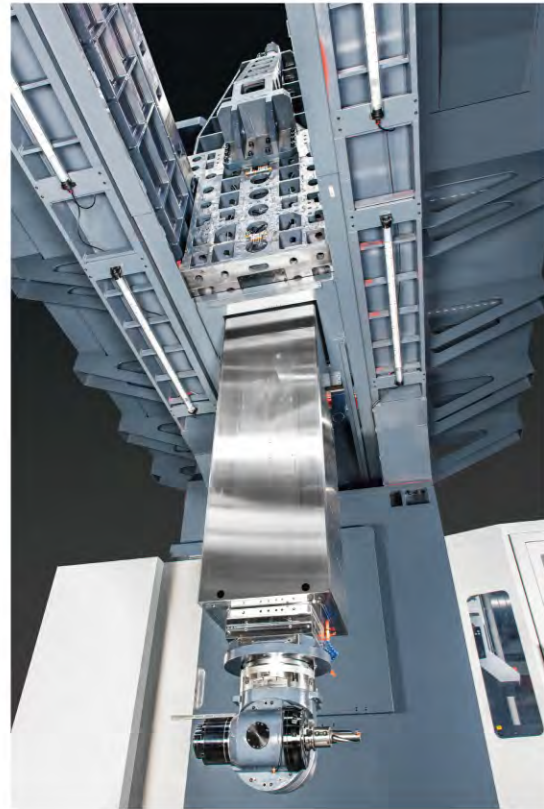

- ▶ **Box-in-Box cross beam design**
 - Double rigidity and cutting anti-vibration characteristics.
 - In a thermal symmetrical structure, the XZ accuracy is not affected by environmental temperature changes.
- ▶ **Hydrostatic Guideway Type (opt.)**
 - The hydraulic system pump high-pressure oil into the ram and enclosed saddle that can provide ultra-low friction provides excellent motion accuracy.
 - Configure hydraulic oil independent cooling system, effectively control the working temperature of hydrostatic oil films.
 - High rigidity provides a high cutting capability.
 - The high damping property reduces the cutting vibration directly.
 - Long service life without wear.
 - Ensure the clamping of the head, providing the best machining rigidity and spindle torque 1500Nm.

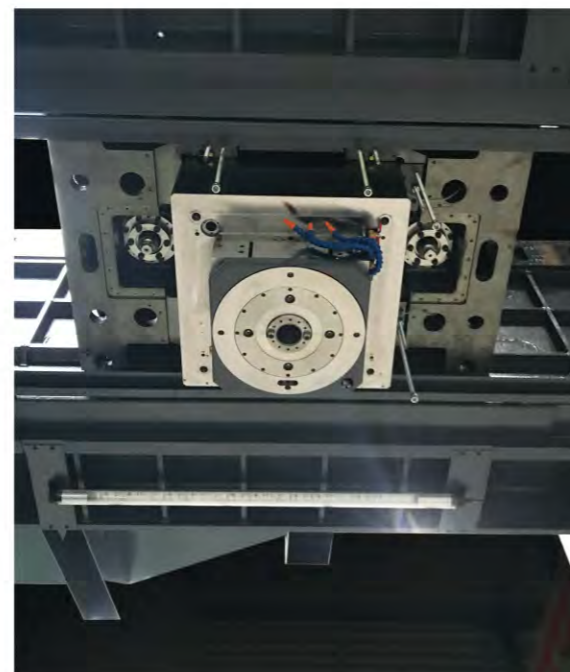
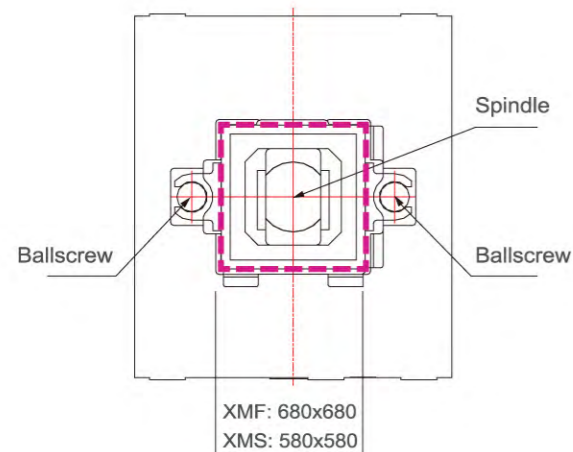

Mill-Turning Integrated Design (opt.)

- Automatic exchange of triple side turning tool head.
- Turning tool holder Capto C8.
- Rotary Table
High speed type
High torque type

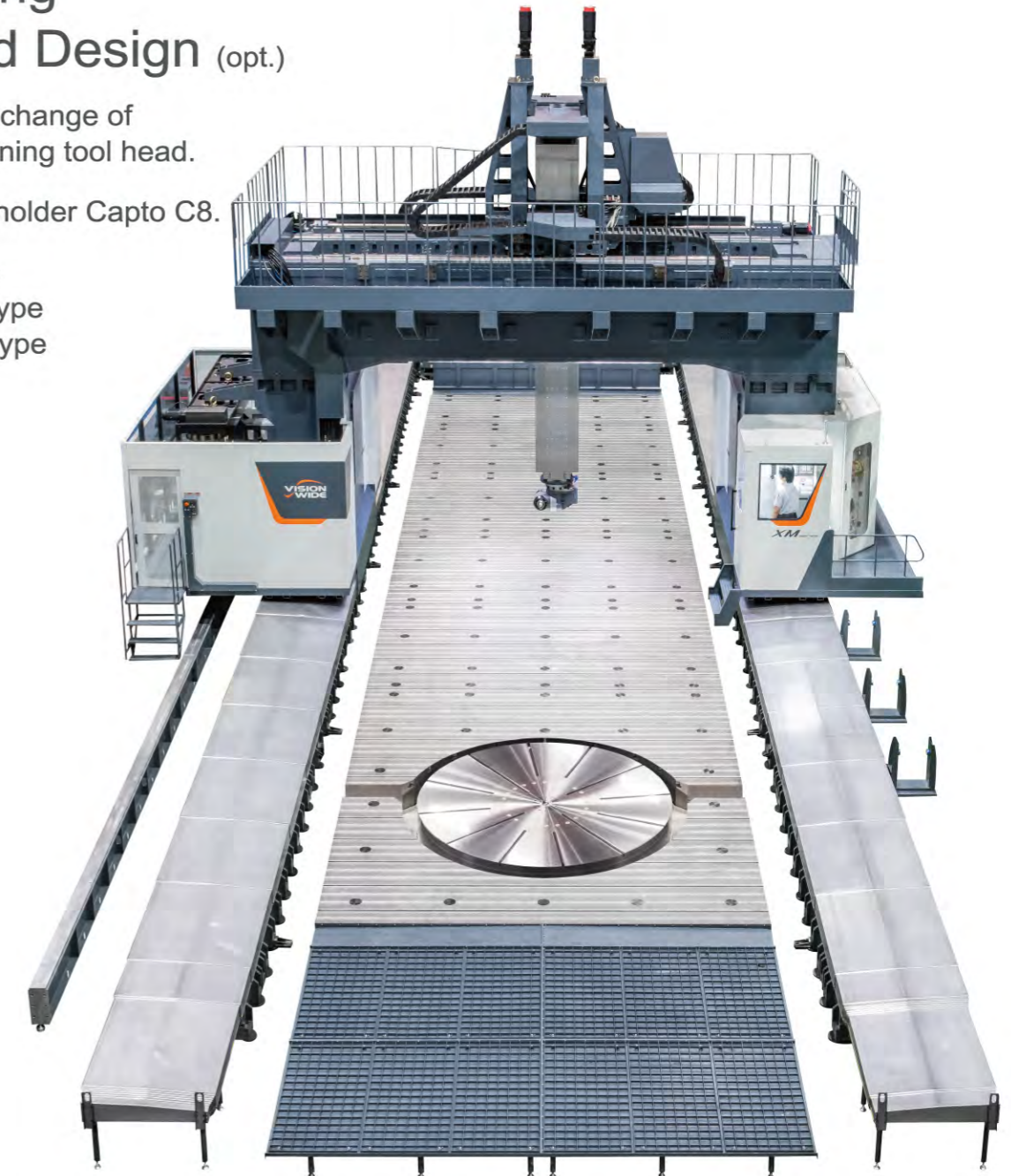

Rotary Table

● Photo: High speed type rotary table

High Torque Type

Table dimension: 3/ 3.5/ 4/ 4.5/ 5m

Max. Table load: 60,000kgs

High Speed Type

Table dimension: 1.5/ 1.8/ 2.2m

Max. Table load: 5,000kgs

FANUC controller

(1) FANUC α il 22, 22/26kW, 4000rpm

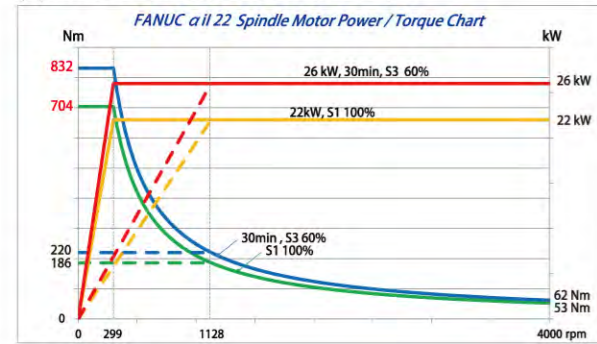

(2) FANUC α il 22, 22/26kW, 6000rpm

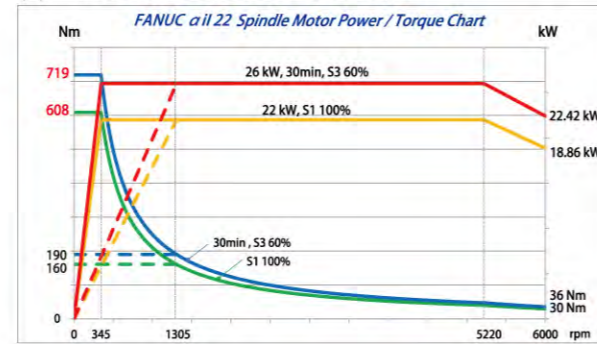

(3) FANUC α il 30, 30/37kW, 4000rpm

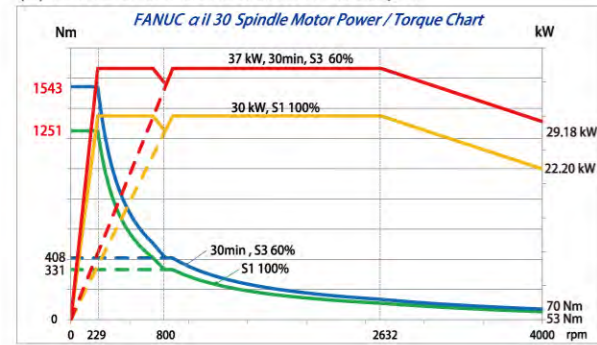

(4) FANUC α il 30, 30/37kW, 6000rpm

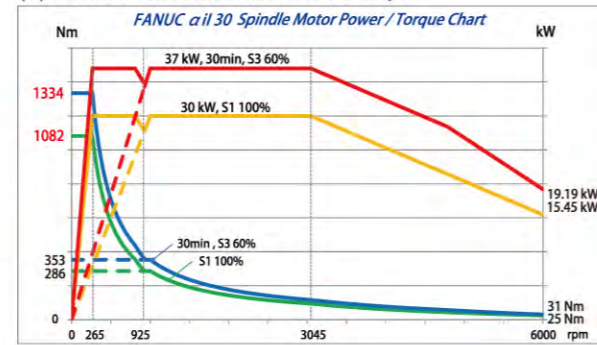

(5) FANUC Bii 180LL, 37/45kW, 8000rpm

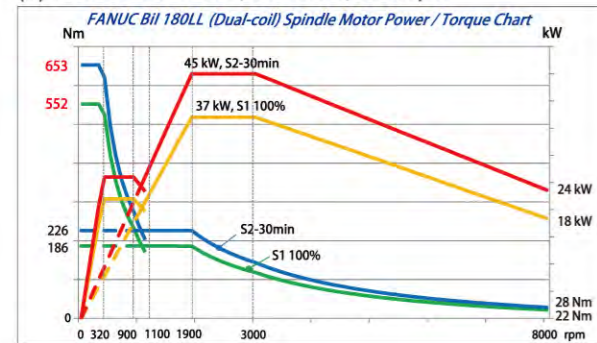

(6) FANUC Bii 160LL, L:18.5/22kW H:30/37kW, 12000rpm

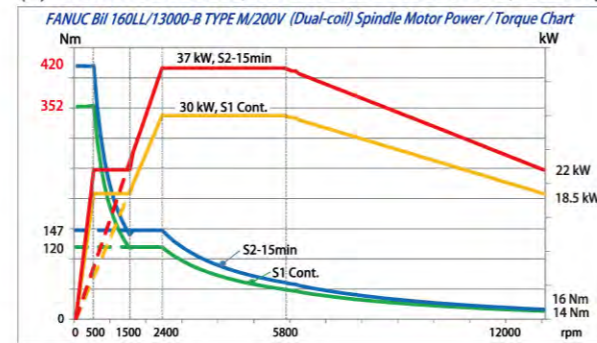

HEIDENHAIN controller

(1) Heidenhain QAN260U, 24/30kW, 4000rpm

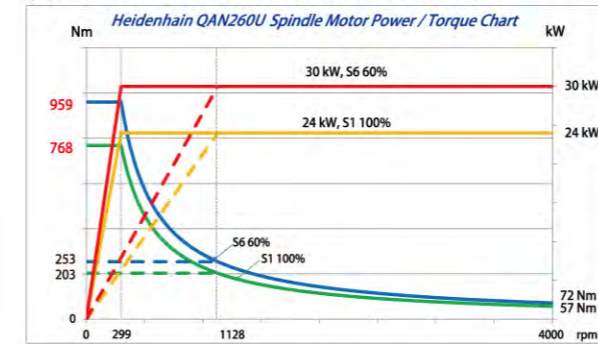

(2) Heidenhain QAN260U, 24/30kW, 6000rpm

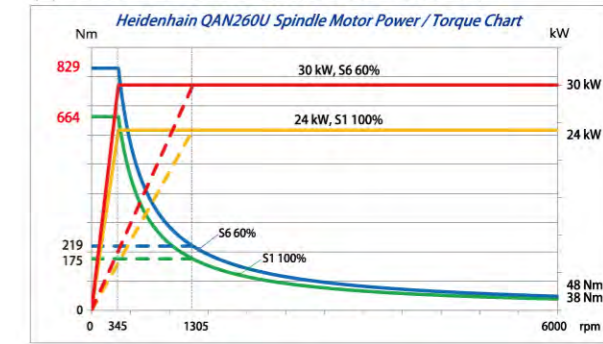

(3) Heidenhain QAN320M, 32/43kW, 4000rpm

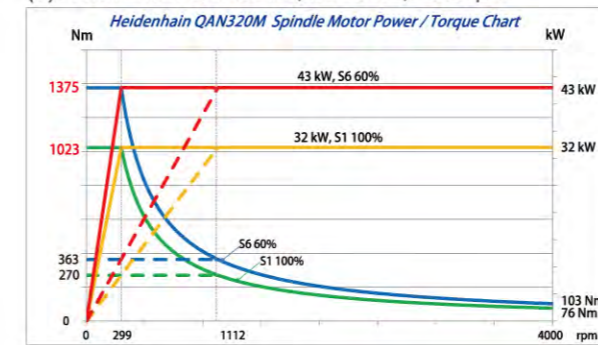

(4) Heidenhain QAN320M, 32/43kW, 6000rpm

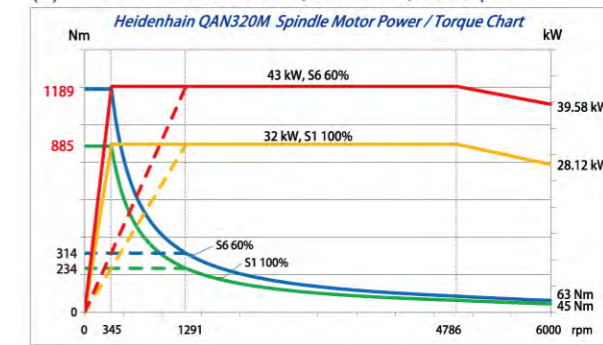

SIEMENS controller

(1) SIEMENS 1PH8137-1xFxx, 22/26.4kW, 4000rpm

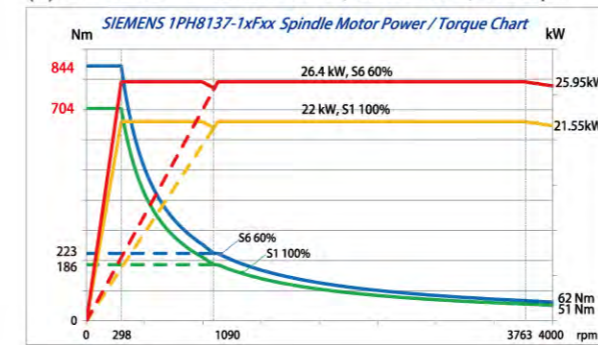

(2) SIEMENS 1PH8137-1xFxx, 22/26.4kW, 6000rpm

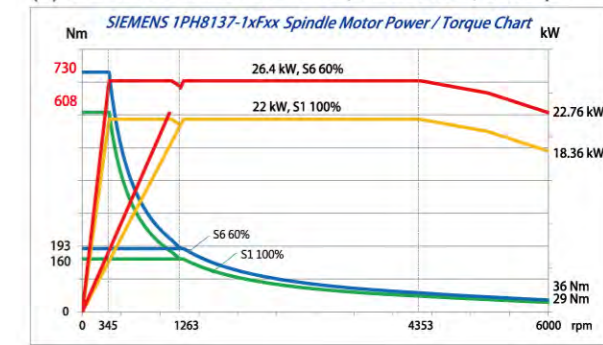

(3) SIEMENS 1PH8163-1xFxx, 30/36kW, 4000rpm

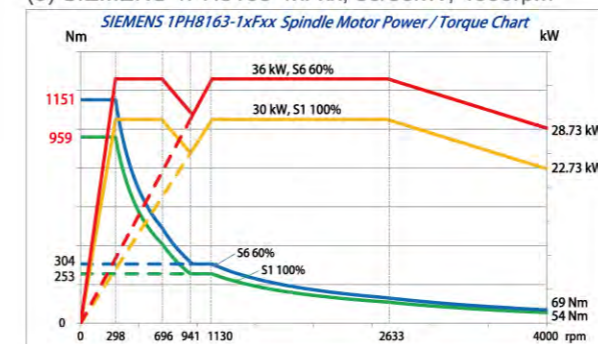

(4) SIEMENS 1PH8163-1xFxx, 30/36kW, 6000rpm

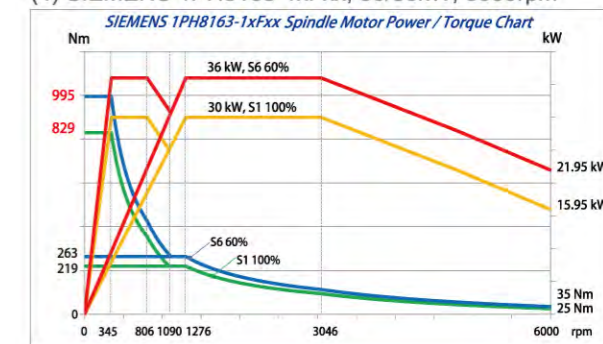

Intelligent Multi-face Machining

5-axis level tool point center management TPCM

Each type of head attachment with tool center point management, takes vertical workpiece as origin benchmark, and converts the workpiece coordinates to any new specified plane of workpiece coordinates automatically.

Auto coordinates tool axis 3D conversion

3-axis mechanical coordinates system can be automatically converted to machining coordinates system, easily achieving face milling, end milling, drilling and rigid tapping machining operations in different direction.

Head attachment dimensions correction

Intelligent compensation on each type of head attachments. The compensation including rotation center, tool size, workpiece coordinates system correction management. It greatly simplifies the complexity of programming and operation to achieve perfect auto multi-angle machining.

Auto Compensation Software

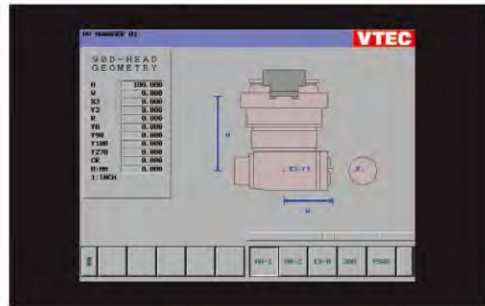

Auto compensation for attachment heads:

- Auto compensating horizontal head center and spindle center.
- Auto compensating mechanism mass center and revolution center.

3D coordinates management:

- 1.V/H tool length and diameter compensation.
- 2.V/H working coordinate affine transformation.
- 3.manual interrupting.
- 4.3D rigid tapping.

Heavy cutting ability

Cutting depth test demonstrated excellent heavy cutting rigidity

test specification: 22/26kW 4,000rpm spindle

Head attachment	Extended head	90 degree angular head	2-axis head
Tool type	BT-50 face milling tool-diameter $\phi 125/5$ edge		
Cutting material	S45C	S45C	
Spindle speed(rpm)	600	600	
Feed rate(mm/min)	1000	1000	
Machining width(mm)	100	100	
Machining depth	4	5	
Removal rate(cc/min)	400	500	



TCPM0.04mm



Auto Multi-Angle Head Attachment

AC 90° angular head



Item	AC 90° angular head	
	G2	G3
Max. speed	3,000rpm	5,000rpm
Max. power	26kW	
Tool clamping	Auto hydraulic clamping	
Head clamping	Auto hydraulic clamping	
C-axis indexing	Auto 1' / 5'	
Machining coolant	External nozzle	External nozzle
Coolant Through Spindle(opt.)	20 bar. / 70 bar.	
A	$\phi 436$	$\phi 435$
B	$\phi 436$	$\phi 512$
C	300	300
D	100	106
E	$\phi 200$	$\phi 200$
F	259	259
G	515.7	539
H	212	212
J	$\phi 352$	$\phi 360$

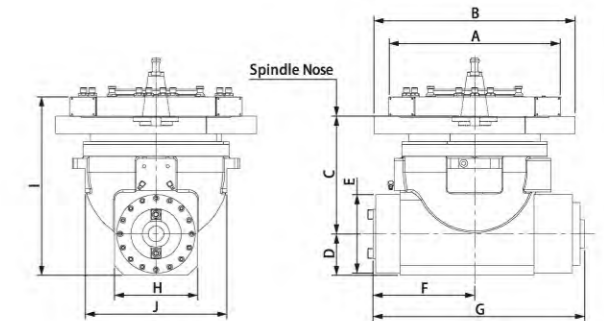

AC 2-axis head



Item	AC 2-axis head	
	G2	G3
Max. speed	3,000rpm	4,000rpm
Max. power	26kW	
Tool clamping	Auto hydraulic clamping	
Head clamping	Auto hydraulic clamping	
C-axis indexing	Auto 1' / 5'	Auto 1' / 5'
B-axis indexing	Auto 5'	Auto 1' / 5'
Machining coolant	External nozzle	Spindle ring cutting coolant system
Coolant Through Spindle(opt.)	20 bar. / 70 bar.	
A	$\phi 436$	$\phi 435$
B	$\phi 436$	$\phi 512$
C	$\phi 200$	$\phi 178$
D	350	258
E	300	281
F	573.5	559
G	388.5	330
H	122.5	106
I	329.5	206
J	627.3	585
K	259	185

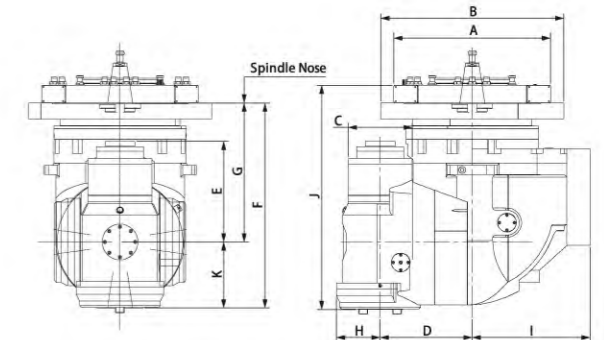

AC extended head



Item	AC extended head 300mm		AC extended head 420mm	
	G2	G3	G2	G3
Max. speed	4,000rpm	5,000rpm	4,000rpm	5,000rpm
Max. power	26kW			
Tool clamping	Auto hydraulic clamping			
Head clamping	Auto hydraulic clamping			
C-axis indexing	Auto 1' / 5'			
Machining coolant	External nozzle	External nozzle	External nozzle	External nozzle
A	$\phi 436$	$\phi 435$	$\phi 436$	$\phi 435$
B	300	300	427	427
C	$\phi 230$	$\phi 230$	$\phi 230$	$\phi 230$
D	$\phi 185$	$\phi 185$	$\phi 185$	$\phi 185$
E	374	381	501	501

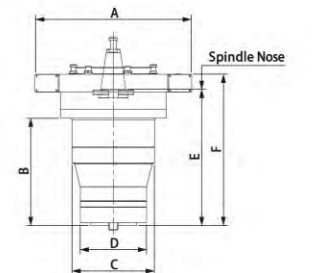

Powerful and Precision Boring Head Attachment

600mm AC 90° spindle extension head



Item	600mm AC 90° spindle extension head
Max. speed	2000 rpm
Max. power	26 kW
Tool clamping	Manual hydraulic clamping
Head clamping	Auto hydraulic clamping
C-axis indexing	(1°) / 5°
Machining coolant	External nozzle
Coolant Through Spindle(opt.)	N/A

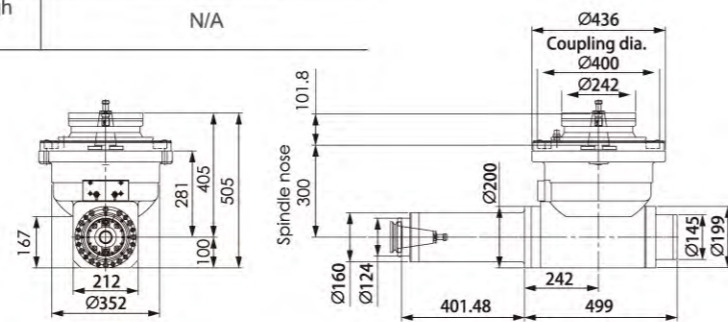

AC 90° angular head (Strong)



Item	AC 90° angular head (Strong)
Max. speed	3,000 rpm
Max. power	26 kW
Tool clamping	Auto hydraulic clamping
Head clamping	Manual /Auto hydraulic clamping
C-axis indexing	5°
Machining coolant	External nozzle
Coolant Through Spindle(opt.)	N/A

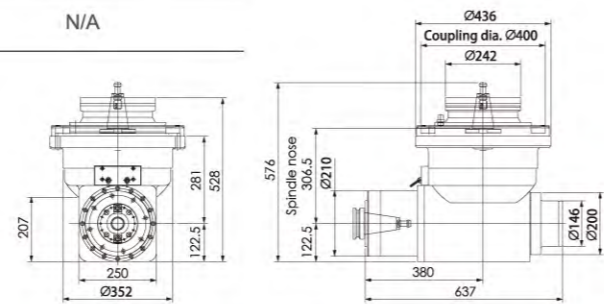

Turning Solutions

High Torque / High Speed Rotary Table

High Torque Type

Table dimension	mm	Φ3,000	Φ3,500	Φ4,000	Φ4,500	Φ5,000
Max. rotary dimension	mm	Φ3,700	Φ4,200	Φ4,700	Φ5,200	Φ6,000
Table load	kg	20,000	20,000	25,000	25,000	30,000
Rated torque (cont./30min)	Nm	90,840/110,400	90,840/110,400	191,200/239,000	191,200/239,000	246,400/308,000

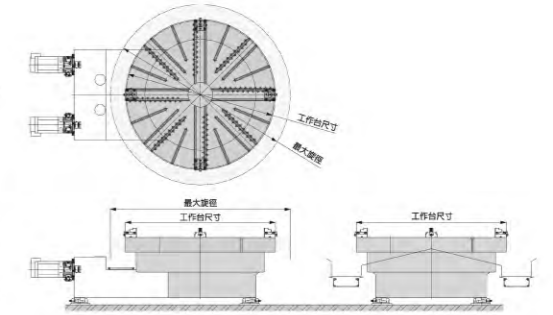

High Speed Type

Table dimension	mm	Φ1,500	Φ1,800	Φ2,200
Table load (Central Region)	kg	3,000	5,000	5,000
Speed	rpm	350	250	200
Rated torque	Nm	4,520	4,520	7,290



Triple Side Turning Head



Item	Triple side turning head
Shank capacity	3
Shank direction	2 Horizontal/ 1 Vertical
Shank Spec.	Capto C8
Head clamping	Auto
Tool clamping	Manual
Machining coolant	External nozzle



3-side turning application



Deep hole turning applications

Best Use of Space

- Moving column type machines use 40 % less space than moving table type machines.
- The tool magazine is located at left side of machine. It move with column, the machine can do tool change at any X position. Shorten the non-machining time.

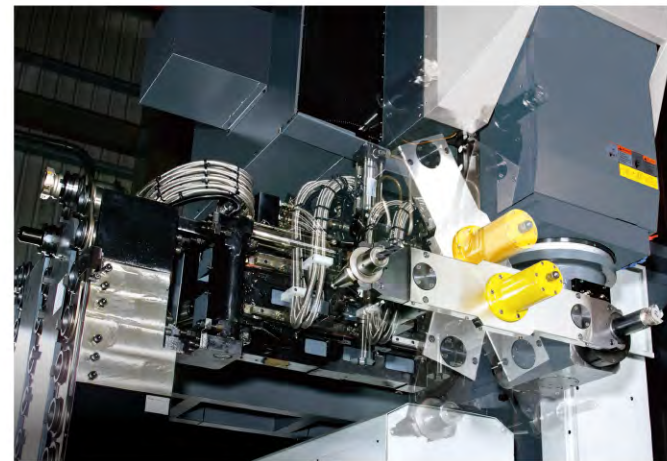

- Automatic tool measuring system, which can measure and correct tool length and tool diameter after tool change, greatly reduce tool setting time.
- The measurement system is stand-alone from the working range to ensure accuracy and service life.
- Repeat positioning accuracy, less than 0.005mm.



- The tool magazine, hydraulic, cooling and lubricating system located on the column side. Easy to do daily maintenance.



Friendly Operating Interface

Wide and convenient work space for set up

- Large workpiece placement space, customized excavation type foundation provide same table height as the ground, which is convenient for workpiece set-up.
- The cooling water and air gun interface are near to the operating side, easy for cleaning.



Provide operators with a safe and simple operating environment

- Confrontable operation room
- Ergonomic swing operation box with easy to operate panel
- Wireless handwheel

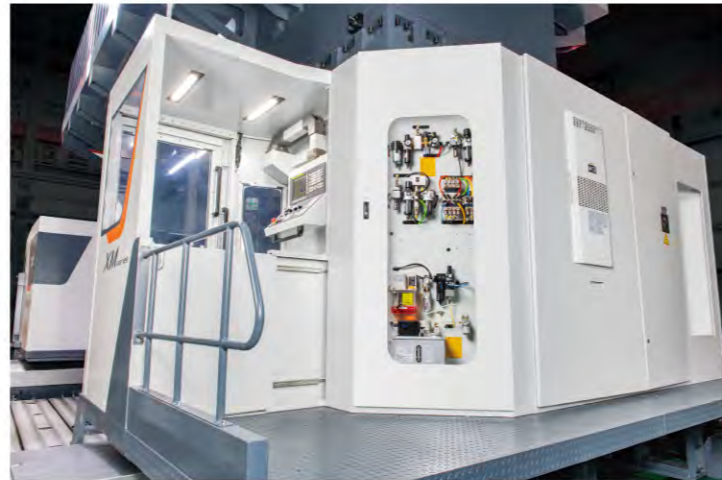

CNC TalkBox

Manufacturing Management System

- Collect product information from the machine
- Supports multiple controllers/multi-brand machines
- Remote production management

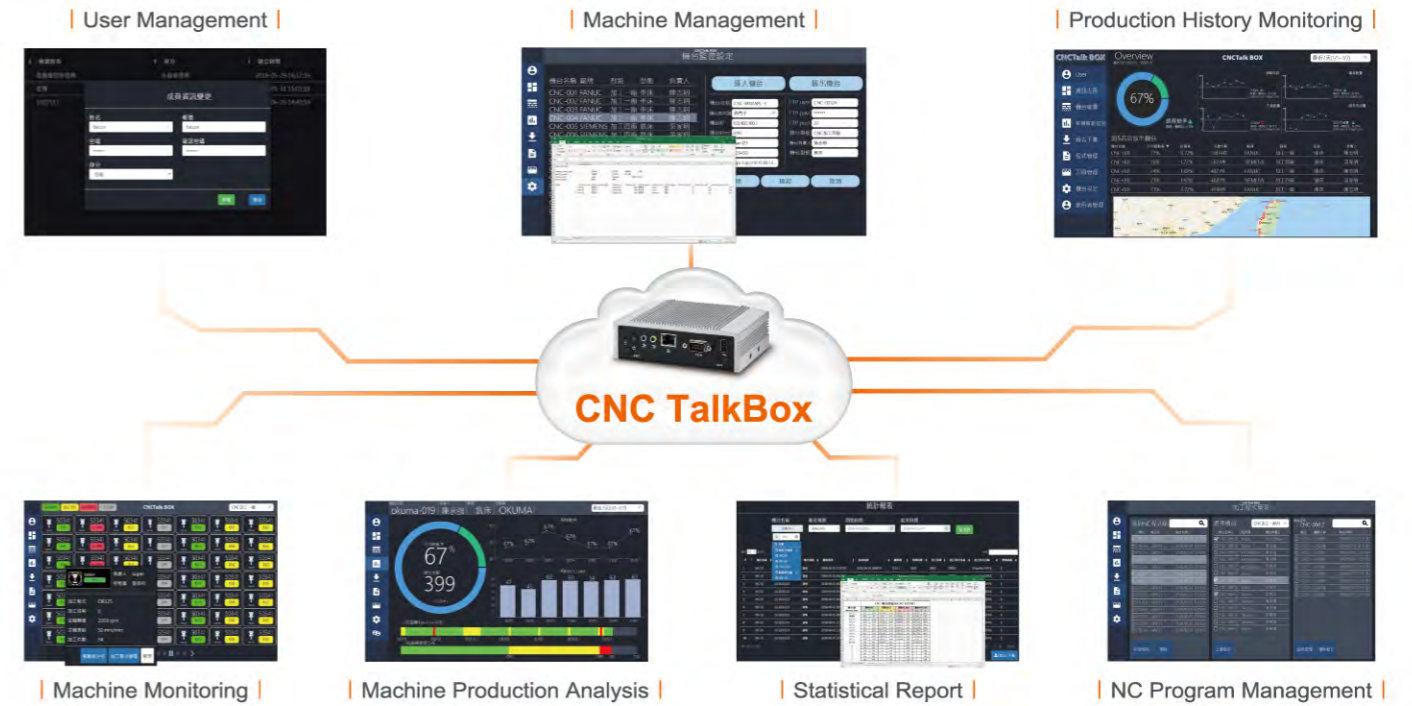

Intelligent Factory Management

CNC TalkBox possesses computing, storage and industrial Internet functions. After computing, the production information can be uploaded to the cloud database or mobile devices to achieve the less hardware managements and the optimal mobile data exchanging capacity.

Economic

Small hardware devices for rapid introduction of industrial Internet of Things (IoT).

Stable

Timely record of production log is a benefit to analyze process and increase production capacity.

Expandable

Complete data collection can make better decisions for process, dispatch, tool and material management.

Machine Dimension

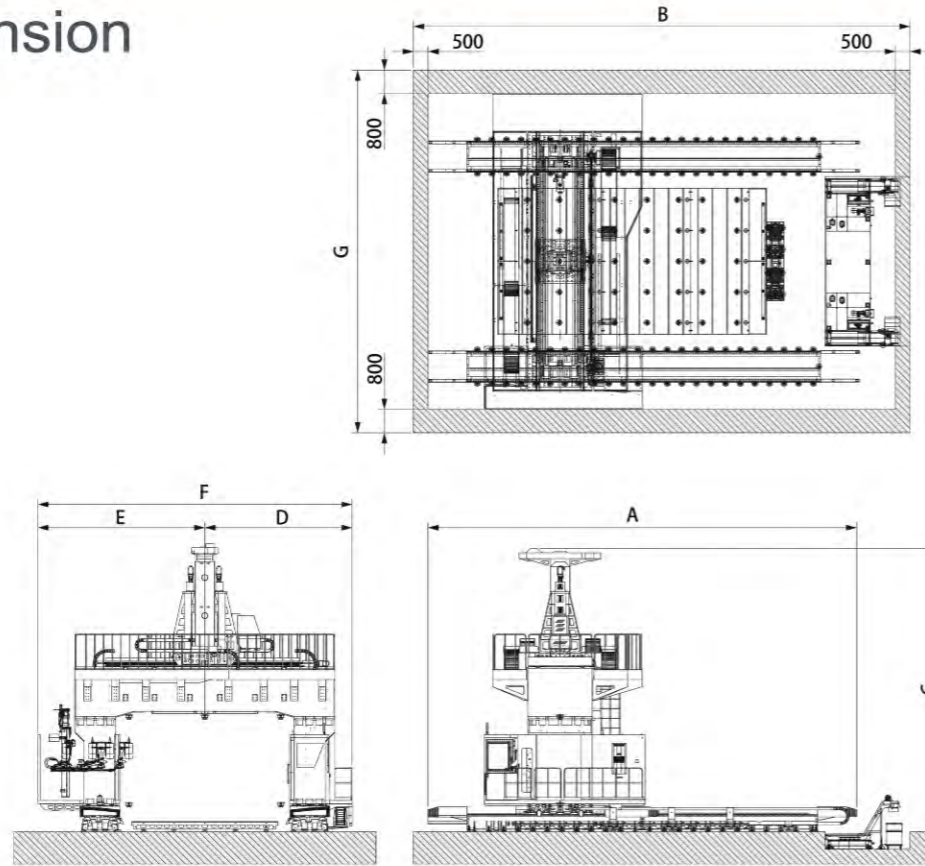
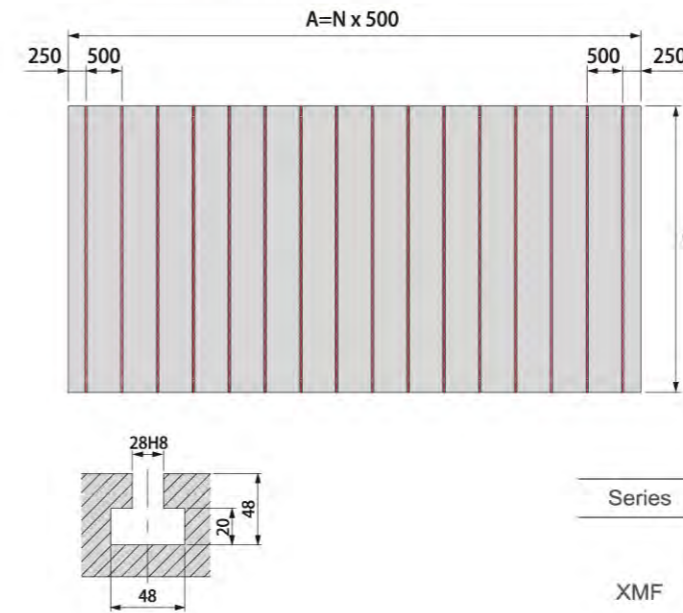

Table & T-slot



Series	Model	A	B	N (pcs.)
XMF	XMF-42	8,000(+1m)~60,000	4,000	16~120 (A/500)
	XMF-47		4,000	
	XMF-52		5,000	
	XMF-57		5,000	
XMS	XMS-37	8,000(+1m)~60,000	3,500	16~120 (A/500)
	XMS-42		4,000	
	XMS-52		5,000	

XMF series

Model	X axis travel	Y axis travel	Z axis travel	A	B	C	D	E	F	G
XMF-42	8,200(+1m)~60,200	4,200	2,500	X+7,480	X+9,800	8,680	4,540	5,215	9,755	11,400
			3,000			9,680				
XMF-47	8,200(+1m)~60,200	4,700	2,500	X+7,480	X+9,800	8,680	4,790	5,465	10,255	11,900
			3,000			9,680				
XMF-52	8,200(+1m)~60,200	5,200	2,500	X+7,480	X+9,800	8,680	5,040	5,715	10,755	12,400
			3,000			9,680				
XMF-57	8,200(+1m)~60,200	5,700	2,500	X+7,480	X+9,800	8,680	5,290	5,965	11,255	12,900
			3,000			9,680				

XMS series

Model	X axis travel	Y axis travel	Z axis travel	A	B	C	D	E	F	G
XMS-37	8,200(+1m)~60,200	3,700	1,500	X+5,060	X+8,500	7,560	4,100	4,455	8,555	10,150
			1,800			7,560				
			2,000			7,560				
			2,200			7,960				
XMS-42	8,200(+1m)~60,200	4,200	1,500	X+5,060	X+8,500	7,560	4,350	4,705	9,055	10,650
			1,800			7,560				
			2,000			7,560				
			2,200			7,960				
XMS-52	8,200(+1m)~60,200	5,200	1,500	X+5,060	X+8,500	7,560	4,850	4,955	9,555	11,650
			1,800			7,560				
			2,000			7,560				
			2,200			7,960				

Tool Shank & Pull Stud

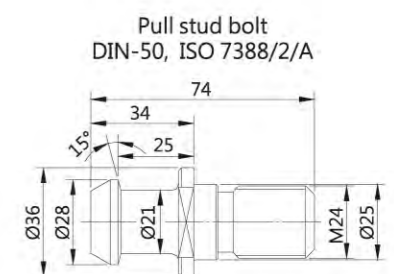
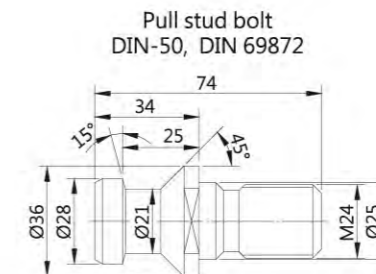
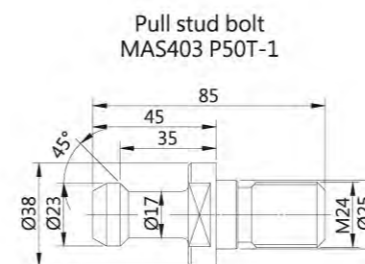
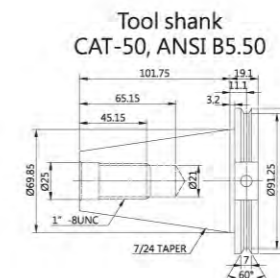
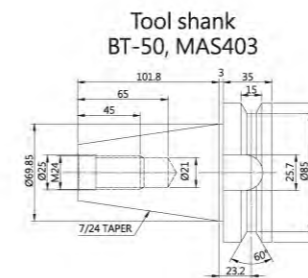

Working Range

Vertical

Model	X axis travel	Y axis travel	Z axis travel	A	B
XMF-42	8,200(+1m) -60,200	4,200	2,500	500	100
			3,000		
XMF-47	8,200(+1m) -60,200	4,700	2,500	500	350
			3,000		
XMF-52	8,200(+1m) -60,200	5,200	2,500	500	100
			3,000		
XMF-57	8,200(+1m) -60,200	5,700	2,500	500	350
			3,000		

* This is gear type spindle travel, Built-in spindle travel is (A-40mm)

Model	X axis travel	Y axis travel	Z axis travel	A	B
XMS-37	8,200(+1m) -60,200	3,700	1,500	100	1,000
			1,800		
			2,000		
			2,200		
XMS-42	8,200(+1m) -60,200	4,200	1,500	100	1,000
			1,800		
			2,000		
			2,200		
XMS-52	8,200(+1m) -60,200	5,200	1,500	100	1,000
			1,800		
			2,000		
			2,200		

* This is gear type spindle travel, Built-in spindle travel is (A-40mm)

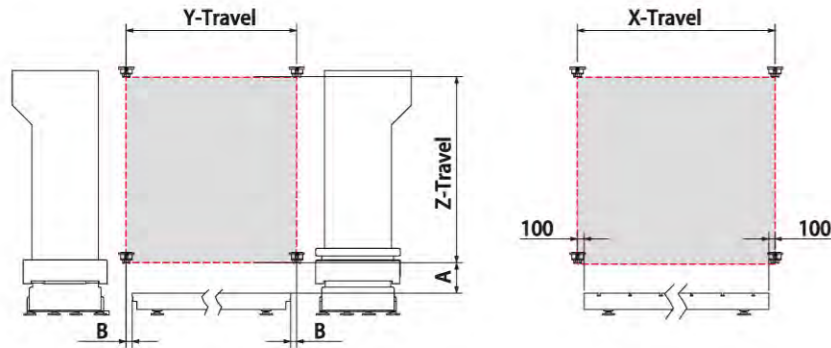

AC 90° head

Model	AC Spec.	X axis travel	Y axis travel	Z axis travel	A	B	C	D
XMF-42	G2	8,200(+1m) -60,200	4,200	2,500	3,682	2,500	200	7,682-59,682
				3,000	3,000			
	G3	8,200(+1m) -60,200	4,200	2,500	3,682	2,500	200	7,682-59,682
				3,000	3,000			
XMF-47	G2	8,200(+1m) -60,200	4,700	2,500	4,182	2,500	200	7,682-59,682
				3,000	3,000			
	G3	8,200(+1m) -60,200	4,700	2,500	4,182	2,500	200	7,682-59,682
				3,000	3,000			
XMF-52	G2	8,200(+1m) -60,200	5,200	2,500	4,682	2,500	200	7,682-59,682
				3,000	3,000			
	G3	8,200(+1m) -60,200	5,200	2,500	4,682	2,500	200	7,682-59,682
				3,000	3,000			
XMF-57	G2	8,200(+1m) -60,200	5,700	2,500	5,182	2,500	200	7,682-59,682
				3,000	3,000			
	G3	8,200(+1m) -60,200	5,700	2,500	5,182	2,500	200	7,682-59,682
				3,000	3,000			

* This is gear type spindle travel, Built-in spindle travel is (B-40mm)

Model	AC Spec.	X axis travel	Y axis travel	Z axis travel	A	B	C	D
XMS-37	G2	8,200(+1m) -60,200	3,700	1,500	3,182	1,500	200	7,682-59,682
				1,800				
				2,000				
				2,200				
XMS-37	G3	8,200(+1m) -60,200	3,700	1,500	3,182	1,500	200	7,682-59,682
				1,800				
				2,000				
				2,200				
XMS-42	G2	8,200(+1m) -60,200	4,200	1,500	3,682	1,500	200	7,682-59,682
				1,800				
				2,000				
				2,200				
XMS-42	G3	8,200(+1m) -60,200	4,200	1,500	3,682	1,500	200	7,682-59,682
				1,800				
				2,000				
				2,200				
XMS-52	G2	8,200(+1m) -60,200	5,200	1,500	4,682	1,500	200	7,682-59,682
				1,800				
				2,000				
				2,200				
XMS-52	G3	8,200(+1m) -60,200	5,200	1,500	4,682	1,500	200	7,682-59,682
				1,800				
				2,000				
				2,200				

* This is gear type spindle travel, Built-in spindle travel is (B-40mm)

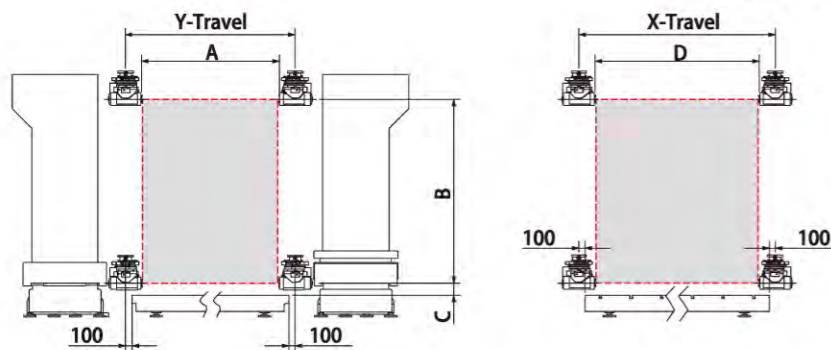

AC 2-axis head (Vertical)

Model	AC Spec.	X axis travel	Y axis travel	Z axis travel	A	B
XMF-42	G2	8,200(+1m) -60,200	4,200	2,500	50	2,377
				3,000		
				2,500		
XMF-42	G3	8,200(+1m) -60,200	4,200	3,000	50	2,877
				2,500		
				3,000		
XMF-47	G2	8,200(+1m) -60,200	4,700	2,500	50	2,377
				3,000		
				2,500		
XMF-47	G3	8,200(+1m) -60,200	4,700	3,000	50	2,877
				2,500		
				3,000		
XMF-52	G2	8,200(+1m) -60,200	5,200	2,500	50	2,377
				3,000		
				2,500		
XMF-52	G3	8,200(+1m) -60,200	5,200	3,000	50	2,877
				2,500		
				3,000		
XMF-57	G2	8,200(+1m) -60,200	5,700	2,500	50	2,377
				3,000		
				2,500		
XMF-57	G3	8,200(+1m) -60,200	5,700	3,000	50	2,877
				2,500		
				3,000		

* This is gear type spindle travel, Built-in spindle travel is (A-40mm)

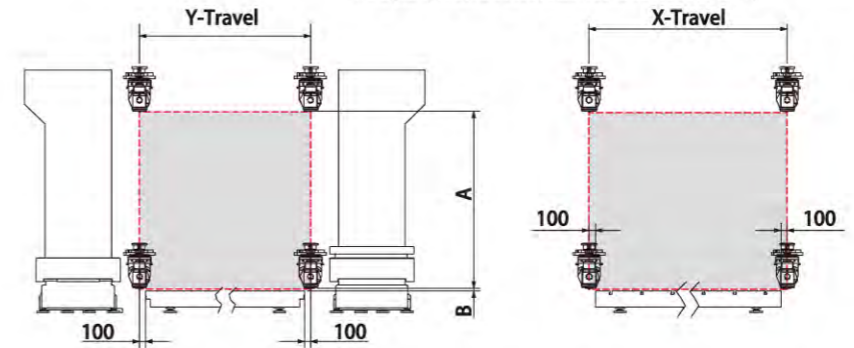

AC 2-axis head (Horizontal)

Model	AC Spec.	X axis travel	Y axis travel	Z axis travel	A	B	C	D
XMF-42	G2	8,200(+1m) -60,200	4,200	2,500	3,682	2,391	309	7,682-59,682
				3,000				
				2,500				
XMF-42	G3	8,200(+1m) -60,200	4,200	3,000	3,682	2,891	236	7,830-59,830
				2,500				
				3,000				
XMF-47	G2	8,200(+1m) -60,200	4,700	2,500	4,182	2,391	309	7,682-59,682
				3,000				
				2,500				
XMF-47	G3	8,200(+1m) -60,200	4,700	3,000	4,182	2,891	236	7,830-59,830
				2,500				
				3,000				
XMF-52	G2	8,200(+1m) -60,200	5,200	2,500	4,682	2,391	309	7,682-59,682
				3,000				
				2,500				
XMF-52	G3	8,200(+1m) -60,200	5,200	3,000	4,682	2,891	236	7,830-59,830
				2,500				
				3,000				
XMF-57	G2	8,200(+1m) -60,200	5,700	2,500	5,182	2,391	309	7,682-59,682
				3,000				
				2,500				
XMF-57	G3	8,200(+1m) -60,200	5,700	3,000	5,182	2,891	236	7,830-59,830
				2,500				
				3,000				

* This is gear type spindle travel, Built-in spindle travel is (B-40mm)

Model	AC Spec.	X axis travel	Y axis travel	Z axis travel	A	B	C	D
XMS-37	G2	8,200(+1m) -60,200	3,700	1,500	3,182	1,500	200	7,682-59,682
				1,800				
				2,000				
				2,200				
XMS-37	G3	8,200(+1m) -60,200	3,700	1,500	3,330	1,500	200	7,830-59,830
				1,800				
				2,000				
				2,200				
XMS-42	G2	8,200(+1m) -60,200	4,200	1,500	3,682	1,500	200	7,682-59,682
				1,800				
				2,000				
				2,200				
XMS-42	G3	8,200(+1m) -60,200	4,200	1,500	3,830	1,500	200	7,830-59,830
				1,800				
				2,000				
				2,200				
XMS-52	G2	8,200(+1m) -60,200	5,200	1,500	4,682	1,500	200	7,682-59,682
				1,800				
				2,000				
				2,200				
XMS-52	G3	8,200(+1m) -60,200	5,200	1,500	4,830	1,500	200	7,830-59,830
				1,800				
				2,000				
				2,200				

* This is gear type spindle travel, Built-in spindle travel is (B-40mm)

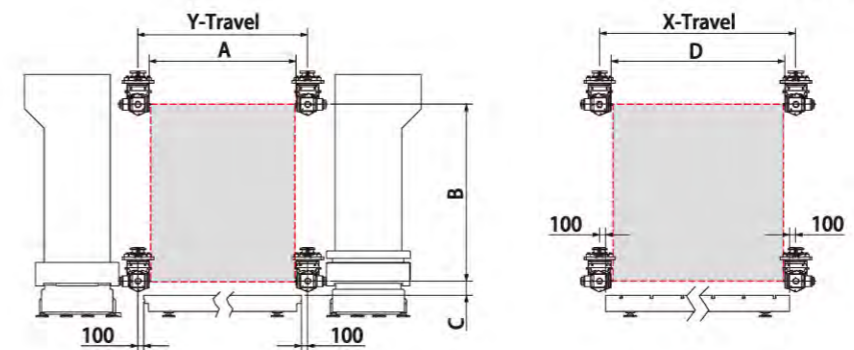

XMF Specification

MODEL	Unit	XMF-42	XMF-47	XMF-52	XMF-57
TRAVEL					
X axis	mm	8,200(+1m)~60,200			
Y axis	mm	4,200	4,700	5,200	5,700
Z axis	mm	2,500 / 3,000(OPT.)			
Distance from spindle nose to table	Ram size	680x680			
	Z axis=2,500	500~3,000			
	Z axis=3,000	500~3,500			
Max. workpiece width	mm	4,600	5,100	5,600	6,100
TABLE					
Dimension (Width x Length)	m	4 x 8~60		5 x 8~60	
T-slot (Dimension x Pitch)	mm	28 x 500			
Max. table load	kg/m ²	5,000			
SPINDLE					
Spindle motor (continuous/30 minute rated)	kW	22 / 26			
Spindle speed	2-step gear	4,000 / 6,000(OPT.)			
	Built-in	8,000(OPT.) / 12,000(OPT.)			
Spindle taper	-	ISO NO.50			
FEEDRATE					
Cutting federate	mm/min	1-10,000			
Rapid traverse (X/Y/Z)	m/min	20 / 20 / 12			
X,Y,Z power capacity	kW	5.5 / 5.5 / 14			
ATC					
ATC capacity	pcs	32 / 40(OPT.) / 60(OPT.)			
Max. tool weight	kg	18			
Max. tool size(Full tools)	mm	Φ125			
Max. tool size(Next pockets empty)	mm	Φ215			
Tool shank	-	ISO NO.50			
Pull stud	-	P50T-1			
OTHER					
Electric power consumption	kVA	85			
Pneumatic input pressure	kg/cm ²	6			
Net weight*	kgs	125,400	129,100	139,500	143,200
Max. floor space (LxWxH)*	m	17 x 11.4 x 8.88	17 x 11.9 x 8.88	17 x 12.4 x 8.88	17 x 12.9 x 8.88

* The specification is X axis travel 8m

Standard accessories and function

- | | | |
|--|--|---|
| 1 Fanuc 0iMF PLUS controller | 10 Air blast through spindle | 21 Footswitch for tool clamping |
| 2 4,000rpm 2-step gear type spindle | 11 Wash gun & pneumatic interface | 22 RJ45 interface |
| 3 Spindle oil cooling system | 12 Cutting coolant system | 23 XYZ-axis travel hard limits protection |
| 4 Z travel | 13 Four piece sheet metal guard | 24 Auto power off |
| XMF : 2,500mm | 14 Wireless manual pulse generator | 25 Remote monitoring software-standard |
| XMS : 2,000mm | 15 Confrontable operation room | 26 Vision Wide FX graphical user interface |
| 5 X Dual linear scale /Z axis linear scale | 16 Screw type chip conveyor on table sides | 27 Foundation pads and bolts kits |
| 6 Y axis Ballscrew supporting device | 17 Caterpillar type chip conveyor / Water tank | 28 Adjustment tool and tool kits |
| 7 Vertical type tool magazine 32 tools | 18 Air conditioning for electrical cabinet | 29 Technical manuals |
| 8 Centralized auto lubrication system | 19 Working lamp | (operation, maintenance manual and circuit diagram) |
| 9 Independent lubrication oil collector | 20 Operation cycle finish and alarm light | |

XMS Specification

MODEL	Unit	XMS-37	XMS-42	XMS-52
TRAVEL				
X axis	mm	8,200(+1m)~60,200		
Y axis	mm	3,700	4,200	5,200
Z axis	mm	1,500(OPT.) / 1,800(OPT.) / 2,000 / 2,200(OPT.)		
Distance from spindle nose to table	Ram size	580 x 580		
	Z axis=1,500	1,000~2,500		
	Z axis=1,800	700~2,500		
	Z axis=2,000	500~2,500		
Distance from spindle nose to table	Z axis=2,200	500~2,700		
Max. workpiece width	mm	4,100	4,600	5,600
TABLE				
Dimension (Width x Length)	m	3.5 x 8 ~ 60	4 x 8 ~ 60	5 x 8 ~ 60
T-slot (Dimension x Pitch)	mm	28 x 500		
Max. table load	kg/m ²	5,000		
SPINDLE				
Spindle motor (continuous/30 minute rated)	kW	22 / 26		
Spindle speed	2-step gear	4,000 / 6,000 (OPT.)		
	Built-in	8,000 (OPT.) / 12,000 (OPT.)		
Spindle taper	-	ISO NO.50		
FEEDRATE				
Cutting federate	mm/min	1-10,000		
Rapid traverse (X/Y/Z)	m/min	20 / 20 / 12		
X,Y,Z power capacity	kW	4.5 / 5.5 / 5.5		
ATC				
ATC capacity	pcs	32 / 40 (OPT.) / 60 (OPT.)		
Max. tool weight	kg	18		
Max. tool size(Full tools)	mm	Φ125		
Max. tool size(Next pockets empty)	mm	Φ215		
Tool shank	-	ISO NO.50		
Pull stud	-	P50T-1		
OTHER				
Electric power consumption	kVA	60		
Pneumatic input pressure	kg/cm ²	6		
Net weight*	kgs	70,000	75,000	84,000
Max. floor space (LxWxH)*	m	16.7 x 10.15 x 7.96	16.7 x 10.65 x 7.96	16.7 x 11.65 x 7.96

* The specification is X axis travel 8m

Optional accessories and function

- | | | |
|--|---|--|
| 1 Fanuc 31iB controller | 10 Without Tool magazine | 20 Sub working table |
| 2 HEIDENHAIN TNC640 controller | 11 Vertical type tool magazine 40T / 60T | 21 Auto tool length measurement |
| 3 SIEMENS ONE controller | 12 Vertical-horizontal type tool magazine 32T/40T/60T | 22 Auto workpiece coordinate measurement |
| 4 6,000 rpm box way type 2-step gear spindle | 13 Coolant through spindle system 20/70 bar | 23 Interface reserved for fourth axis |
| 5 8,000rpm Built-in spindle | 14 Oil skimmer | 24 Transformer |
| 6 12,000rpm Built-in spindle | 15 Oil mist cooling device | 25 AC attachment head |
| 7 Z axis travel | 16 Spindle ring cutting coolant device | 26 Multi-heads magazine |
| XMF : 3,000mm | (for no head attachment) | 27 Anti-collision and |
| XMS : 1,500/ 1,800/ 2,200mm | | proecess simulation software |
| 8 Y axis linear scale | 17 Z-axis retract function at power failure | 28 Remote monitoring software-standard |
| 9 Z axis hydrostatic guideway | 18 Helical bladed screw conveyor on table sides | |
| | 19 Chip cart | |